Resistance, Inductance, & Capacitance in AC Circuits

A magnetic field builds up around a conductor when current is flowing. Due to a phenomenon called self induction, the magnetic field caused by current flow opposes a change in the current flow. In an ac circuit where the voltage is constantly changing the magnetic flux around the conductors is in constant motion and results in an opposition to current flow called *inductive reactance*. An electric field builds up in the space between two conductors when there is a voltage difference between the two conductors. If voltage is changing between two conductors, the current flow in the conductors experiences an opposition called *capacitive reactance*. The combined effect of wire resistance, inductive reactance, and capacitive reactance in an ac circuit is called *impedance*. This *Tech Note* discusses resistance, inductance, and capacitance in alternating current circuits, how impedance is determined, and the overall influence these factors have on current flow. For a detailed discussion of inductors refer to *Tech Note 514*, and for a detailed discussion of capacitors refer to *Tech Note 513*.

Inductance: An *inductor* is a coil of wire usually wound around a steel core. Self induction, caused by current flow, creates a reverse voltage that tries to prevent a change in current flow. Inductance will try to prevent current from increasing. Inductance will also try to prevent current from decreasing. An inductor is illustrated in Figure 221.1.

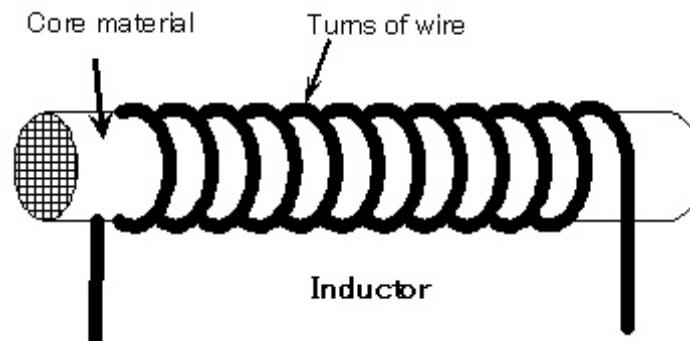

Figure 221.1 An inductor is a coil of wire through which current passes. Generally a steel core passes through the center of the coil and around the outside of the coil to provide a path for the magnetic field created when current flows through the coil.

The *Henry* is the unit of measure of inductance. The Henry is a fairly large unit and typical inductors used in power circuits have values generally measured in millihenries (mh). The symbol of inductance is the letter **L**. To get more inductance in a circuit connect individual inductors in series. For example, if 50 mh of inductance is needed in a circuit, two 25 mh inductors can be connected in series. One Henry of inductance exists when a change in current level within a conductor of one ampere per second results in one volt being produced to oppose the supply voltage. The units of one Henry are volt seconds per ampere.

The effect of an inductor on an alternating current circuit is called *inductive reactance* which has the symbol X_L . The unit of inductive reactance is the Ohm. Equation 221.1 is used to convert an inductance in Henries to inductive reactance. The letter f in the equation is the frequency which is 60 Hz for power circuits, and the letter L is inductance in Henries.

$$X_L = 2 \times \pi \times f \times L \quad \text{Equation 221.1}$$

Example: Determine the inductive reactance of a 25 mh inductor in a 60 Hz alternating current circuit.

$$X_L = 2 \times 3.14 \times 60 \text{ Hz} \times 0.025 \text{ h} = 9.42 \Omega$$

Inductive reactance can be substituted for resistance in Ohm's law to determine the current flow in a circuit if the voltage is known. Equation 221.2 is simply Ohm's law with inductive reactance (X_L) substituted in place of resistance (R). Figure 221.2 shows an inductor in a 120 volt 60 Hz circuit where the inductive reactance (X_L) is 8 ohms. The current flow in the circuit is 15 amperes.

$$I = \frac{E}{X_L} \quad \text{Equation 221.2}$$

Example: The inductive reactance of the circuit of Figure 221.2 was determined to be 8 ohm, and with the circuit energized at 120 volts, 60 Hz ac, the current flow will be 15 amperes.

$$\text{Current} = \frac{\text{Voltage}}{X_L} = \frac{120 \text{ V}}{8 \Omega} = 15 \text{ A}$$

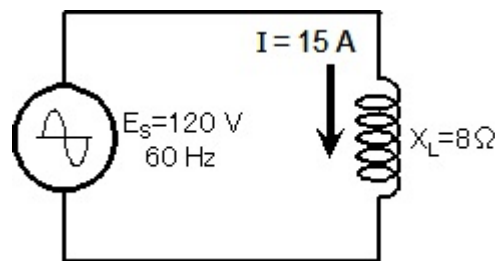

Figure 221.2 A 25 mh inductor, with a value of inductive reactance of 8 ohms, in a 120 volt 60 Hz circuit will draw 15 amperes.

Capacitance A capacitor is two metal plates separated by an insulator called a dielectric as illustrated in Figure 221.3. The symbol for a capacitor in a circuit is also shown in Figure 221.3. Current cannot flow from one plate to the other, but the electric field on one plate will have an effect on the voltage level of the other plate. When the voltage is changing, current will flow in each half of the circuit. If a battery is connected to a capacitor, current will flow in the circuit

until a voltage builds up on the plates of the capacitor equal to the voltage of the battery. Then current will no longer flow. If the battery is disconnected from the circuit, the voltage will remain on the plates of the capacitor. The capacitor is considered to be charged. If a resistance is placed across the terminals of a charged capacitor current will flow through the resistor until the charge on the capacitor is depleted.

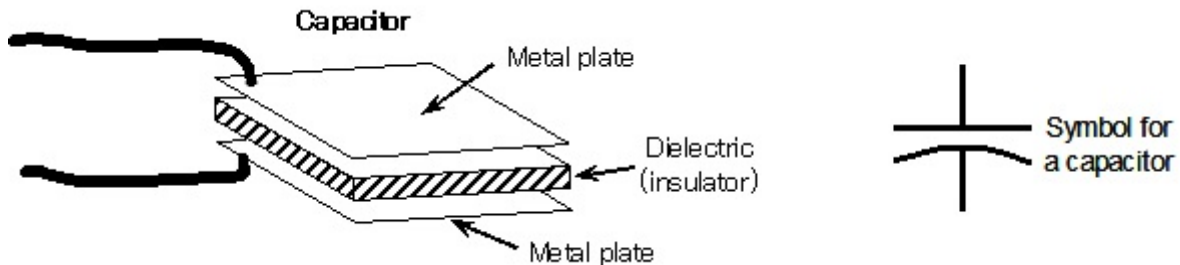

Figure 221.3 A capacitor consists of two metal plates separated by an insulator called a dielectric. The symbol for a capacitor is a straight line next to a curved line.

The **Farad** is the unit of measure of capacitance. The Farad is a very large unit and typical capacitors used in power circuits have values generally measured in microfarads (μf). The symbol of capacitance is the letter **C**. To get more capacitance in a circuit connect individual capacitors in parallel. For example, if 60 μf of capacitance is needed in a circuit, two 30 μf capacitors can be connected in parallel. One Farad of capacitance exists when there is one volt between two conductors (usually metal plates) separated by an insulator (dielectric) with one coulomb of charge. The units of one Farad are ampere seconds per volt.

The effect of a capacitor on an alternating current circuit is called *capacitive reactance* which has the symbol X_C . The unit of capacitive reactance is the Ohm. Equation 221.3 is used to convert a capacitance in Farads to capacitive reactance. The letter **f** in the equation is the frequency which is 60 Hz for power circuits and the letter **C** is capacitance in Farads.

$$X_C = \frac{1}{2 \times \pi \times f \times C} \tag{Equation 221.3}$$

Example: Determine the capacitive reactance of a 60 μf capacitor in a 60 Hz alternating current circuit. Capacitance in microfarads must be converted to capacitance in farads. Divide 60 μf by 1,000,000. The result will be 0.00006 F.

$$X_C = \frac{1}{2 \times 3.14 \times 60 \text{ Hz} \times 0.00006 \text{ F}} = 44.2 \text{ ohm}$$

Capacitive reactance can be substituted for resistance in Ohm’s law to determine the current flow in a circuit if the voltage is known. Equation 221.4 is Ohm’s law with capacitive reactance (X_C) substituted in place of resistance (R). Figure 221.4 shows a capacitor in a 120 volt 60 Hz circuit where the capacitive reactance (X_C) is 20 ohms. The current flow in the circuit is 6 amperes.

$$I = \frac{E}{X_C}$$

Equation 221.4

Example: The capacitive reactance of the circuit of Figure 221.4 is 20 ohm, and with the circuit energized at 120 volts, 60 Hz ac, the current flow will be 6 amperes using Equation 221.4.

$$\text{Current} = \frac{\text{Voltage}}{X_C} = \frac{120 \text{ V}}{20 \Omega} = 6 \text{ A}$$

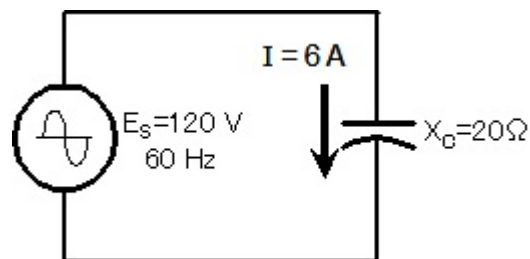

Figure 221.4 A capacitor with a value of 20 ohms in a 120 volt 60 Hz ac circuit will draw 6 amperes.

Impedance Typical alternating current circuits will have resistance (R) combined with inductive reactance (X_L) or capacitive reactance (X_C), or both. Even though all of these quantities are in the unit of Ohms, they cannot be added arithmetically because they act differently on the current in the circuit. Putting inductive reactance or capacitive reactance in a circuit along with resistance is like swimming across a river with a strong current. Instead of reaching the opposite bank directly across from the starting point, the swimmer will reach the opposite bank somewhere down stream. An impedance diagram is used to combine the effect of resistance, inductive reactance, and capacitive reactance in an alternating current circuit. As it turns out in a *series* circuit such as the one shown in Figure 221.5, inductive reactance will subtract from the capacitive reactance. In the impedance diagram, the resistance will be the horizontal side of a right triangle and the net reactance ($X_L - X_C$) will be the vertical side of the right triangle. Their combined effect on an alternating current circuit is called the *impedance* (Z), which is the hypotenuse of the right triangle. The formula for solving for the length of the hypotenuse of a right triangle is used to solve for the impedance when the values of resistance, inductive reactance, and capacitive reactance are known in a series circuit, as shown in Equation 221.5. This equation only works when the resistance, inductive reactance, and capacitive reactance are in series. Determining impedance when these components are arranged in parallel is discussed in *Tech Note 222*.

$$Z = \sqrt{R^2 + (X_L - X_C)^2}$$

Equation 221.5

Inductive reactance in a circuit opposes a change in current level, therefore when a voltage is applied to the circuit, current flow is delayed by some short time interval depending upon the amount of inductive reactance in the circuit. The voltage is said to be leading the current.

When plotting inductive reactance (X_L) in an impedance diagram the inductive reactance is drawn pointing up at $+90^\circ$. Capacitive reactance in a circuit retards the build up of voltage on the capacitor plates since current must flow first to build the charge. When a voltage is applied to a circuit with capacitance, the build up of voltage is delayed by some short time interval depending upon the amount of capacitive reactance in the circuit. The current is said to be leading the voltage. When plotting capacitive reactance (X_C) in an impedance diagram the capacitive reactance is drawn pointing down at -90° .

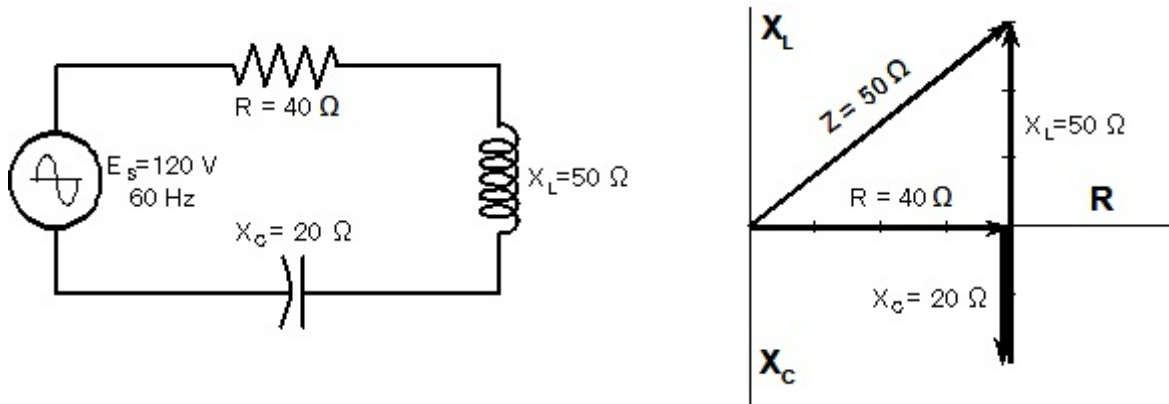

Figure 221.5 In the case of an ac series circuit, the resistance (R) is drawn on the horizontal axis of the impedance diagram, the inductive reactance (X_L) is drawn pointing up on the vertical axis, and the capacitive reactance (X_C) is drawn pointing down on the vertical axis.

Example: Determine the impedance of a 60 Hz, 120 volts ac circuit where there is a resistance (R) of 40 ohm in series with an inductive reactance (X_L) of 50 ohm, and a capacitive reactance (X_C) of 20 ohm as illustrated in Figure 221.5. Use Equation 221.5 and the value turns out to be 50 ohm.

$$Z = \sqrt{40^2 + (50 - 20)^2} = 50\Omega$$

Impedance can be substituted for resistance in Ohm’s law to determine the current flow in a circuit if the voltage is known. Equation 221.6 is Ohm’s law with impedance (Z) substituted in place of resistance (R). This equation determines only the magnitude of the current. The current and voltage sine waves in this ac circuit are no longer lined up with each other when there is reactance in the circuit along with resistance. One complete cycle of a sine wave is 360° . With reactance in the circuit the current and voltage sine waves will be shifted from each other by an amount ranging from more than 0° but less than 90° . This is illustrated in Figure 221.6.

$$I = \frac{E}{Z}$$

Equation 221.6

Example: Determine the impedance of a 60 Hz, 120 volts ac circuit where there is a resistance (R) of 40 ohm in series with an inductive reactance (X_L) of 50 ohm, and a capacitive reactance (X_C) of 20 ohm as illustrated in Figure 221.5 yielding an impedance of 50 ohm. Using Equation 211.6, the current flow in the circuit is 2.4 amperes.

$$\text{Current} = \frac{\text{Voltage}}{Z} = \frac{120 \text{ V}}{50 \Omega} = 2.4 \text{ A}$$

Current and Voltage in an ac Circuit: When there is resistance along with either capacitive reactance or inductive reactance, a right triangle is formed with the impedance diagram as shown in Figure 221.5. The angle θ between the impedance (hypotenuse) and the resistance (adjacent side) is of particular importance. When there is either capacitance or inductance in an alternating current circuit, the current sine wave will either lead ahead or lag behind the voltage sine wave. Current and voltage sine waves will be offset by this same angle θ . An alternating current circuit consisting of a resistor and an inductor in series, and another with a resistor and a capacitor in series are shown in Figure 221.6. The alternating current circuit with the inductive reactance will have the current lagging the voltage by the angle θ . The alternating current circuit with the capacitive reactance will have the current leading the voltage by the angle θ .

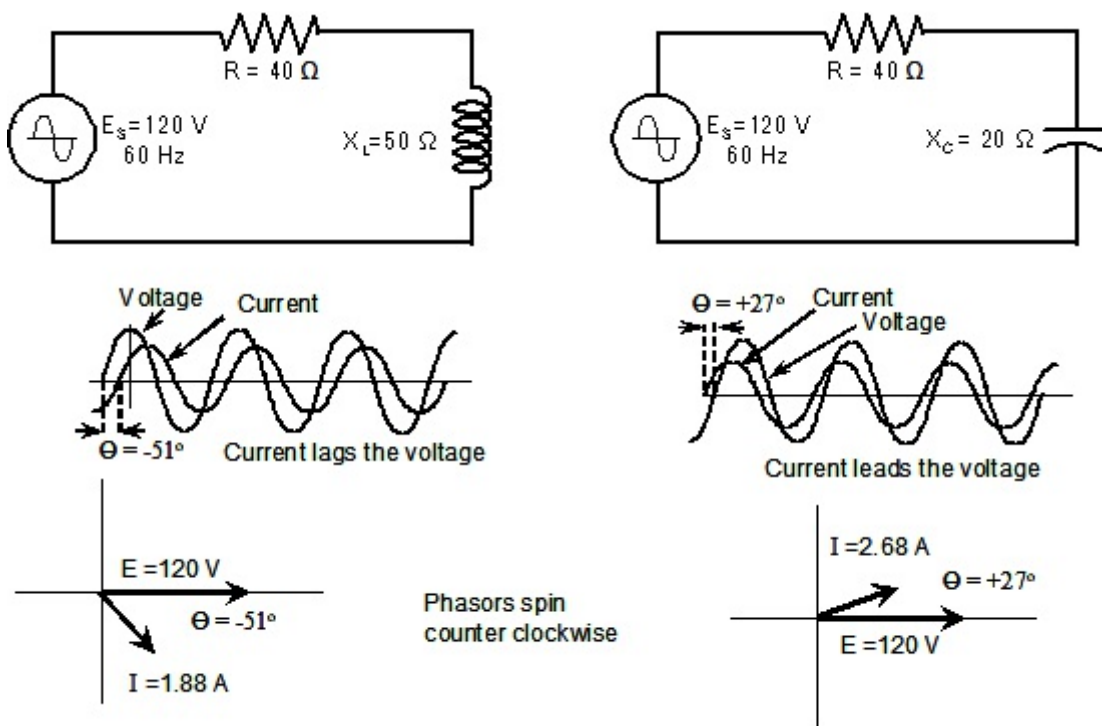

Figure 221.6 When an ac circuit consists of resistance and inductance as represented by the diagram on the left, the current lags behind the voltage by some angle θ . When the circuit consists of resistance and capacitance as represented by the diagram on the right, the current leads the voltage by some angle θ .

Trigonometry Lesson It is important at this point to learn the three basic trigonometry equations for a right triangle. If two sides of a right triangle are known, any angle can be determined. If an angle and a side are known, the length of any other side can be determined. These three equations are sine, cosine, and tangent. Figure 221.7 shows a right triangle with the angle Θ indicated. The hypotenuse of the triangle is the impedance. The horizontal side (resistance) is called the side adjacent. The vertical side (reactance) is called the side opposite. The tangent of the angle Θ is the side opposite (reactance) divided by the side adjacent (resistance) given by Equation 221.7. The sine of the angle is given by Equation 221.8 which is the side opposite (reactance) divided by the hypotenuse (impedance). Equation 221.9 is for the cosine which is the side adjacent (resistance) divided by the hypotenuse (impedance).

$$\text{Tan } \Theta = \frac{\text{side opposite}}{\text{side adjacent}} \quad \text{Equation 221.7}$$

$$\text{Sin } \Theta = \frac{\text{side opposite}}{\text{hypotenuse}} \quad \text{Equation 221.8}$$

$$\text{Cos } \Theta = \frac{\text{side adjacent}}{\text{hypotenuse}} \quad \text{Equation 221.9}$$

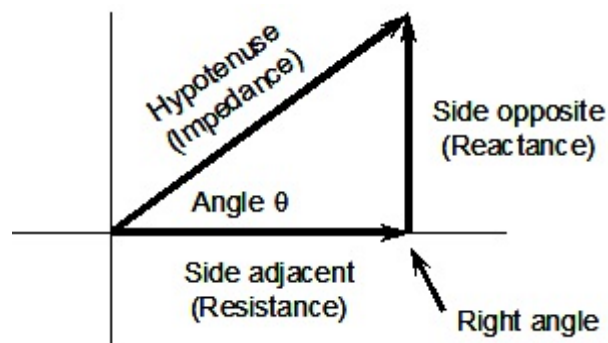

Figure 221.7 Sine, Cosine, and Tangent of the angle Θ are functions of a right triangle, that can be used to solve for any angle if two sides are known, and for any side or angle if a side and angle are known.

If the length of the sides of the right triangle are known, then the angle can be found. This process is called finding the inverse of the sine, cosine, or tangent. This can be done using any calculation with trigonometry functions. The process is represented differently on different calculators. It may be represented as $\Theta = \text{Cos}^{-1}$. It may be represented as $\Theta = \text{ArcCos}$, or it may be represented as $\Theta = \text{ACos}$. Equation 221.10 is used to determine the angle of the right triangle when the side opposite and the hypotenuse are known. Equation 221.11 is used to determine the angle of the right triangle when the side adjacent and the hypotenuse are known. Equation 221.12 is used to determine the angle of the right triangle when the side opposite and the side adjacent are known.

$$\Theta = \text{Sin}^{-1} \frac{\text{Side Opposite}}{\text{hypotenuse}} \quad \text{Equation 221.10}$$

$$\Theta = \text{Cos}^{-1} \frac{\text{Side Adjacent}}{\text{hypotenuse}} \quad \text{Equation 221.11}$$

$$\Theta = \text{Tan}^{-1} \frac{\text{Side Opposite}}{\text{Side Adjacent}} \quad \text{Equation 221.12}$$

Example: Determine the angle Θ for the circuit represented in Figure 221.5. The angle Θ can be found in any one of three ways. Pick whatever formula you like best. The net reactance in Figure 221.5 is 30 ohm (50 ohm – 20 ohm).

$$\Theta = \text{Sin}^{-1} \frac{30}{50} = 36.9^\circ$$

$$\Theta = \text{Cos}^{-1} \frac{40}{50} = 36.9^\circ$$

$$\Theta = \text{Tan}^{-1} \frac{30}{40} = 36.9^\circ$$

Phasor Algebra: The impedance (Z) in Figure 221.5 can be represented as rectangular coordinates by giving the magnitude of the horizontal and the vertical lines from the impedance diagram of Figure 221.5. This two dimensional algebra is called *complex algebra*. The horizontal axis (resistance) is called the *real* axis and the vertical axis (reactance) is called the *imaginary* axis. Any value on the vertical (imaginary) axis is multiplied by the imaginary number square root of -1. You probably learned in school that the square root of -1 was represented by the lower case letter *i*. But in electrical engineering, the lower case *i* is current, so electrical engineers represent the square root of -1 with the lower case letter *j*. Representing the impedance in Figure 221.5 in the *rectangular form* is as follows:

$$Z = 40 + j30 \quad (\text{rectangular form})$$

When impedances are connected in series such as the circuit of Figure 221.5, the total impedance is the sum of the individual components added together in rectangular form as indicated by Equation 221.13. For the example circuit of Figure 221.5 the resistance is 40, the inductive reactance is +j50 and the capacitive reactance is -j20. The impedance of that circuit is 40 + j30.

$$Z = Z_1 + Z_2 + Z_3 + \quad \text{Equation 221.13}$$

$$Z = 40 + j50 - j20 = 40 + j30$$

Example: Two components are connected in series as shown in Figure 221.8 and have an impedance (Z_1) of $20 - j10$ and impedance (Z_2) of $5 + j15$. The total impedance of the circuit will be $25 + j5$.

$$\begin{array}{r} 30 - j10 \\ 5 + j15 \\ \hline 25 + j5 \end{array}$$

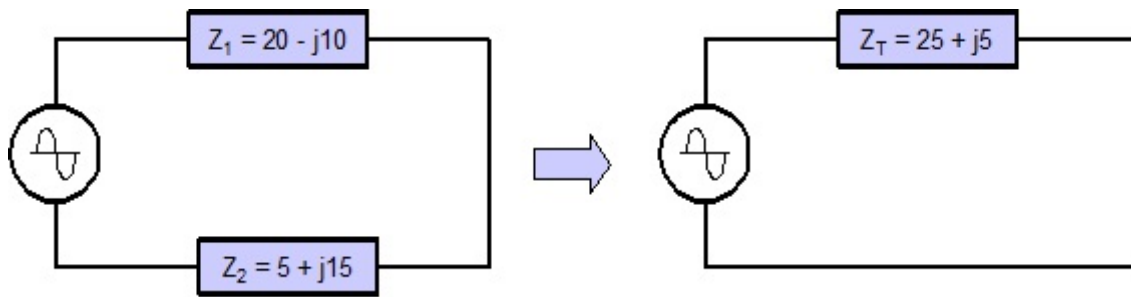

Figure 221.8 Impedances that are connected in series and represented in rectangular form can be added together to give the total impedance of the circuit.

Polar or Phasor Notation: A disadvantage of representing the impedance in rectangular form is that we do not see the actual magnitude of the impedance. Another way to represent the impedance is with its magnitude followed by the angle Θ . For Figure 221.5, the impedance is 50 angle $+36.9^\circ$. This is called *polar form* and in electrical engineering it is called a *phasor*. Phasors can't be added or subtracted, but they can be multiplied and divided. This makes them handy when using Ohm's law or the power formula. A typical way to represent a phasor is as follows for the impedance of Figure 221.5. Examples of how to convert from polar form to rectangular form is discussed at the end of this *Tech Note*.

$$Z = 50 \angle +36.9^\circ \quad (\text{polar form})$$

Multiplying and Dividing Phasors: The voltage in the circuit of Figure 221.5 can be represented by a phasor with the magnitude 120 and an angle of 0° . The impedance can be represented by a phasor with the magnitude 50 and an angle of $+37^\circ$. To get the current, use Ohm's law and divide the voltage phasor by the impedance phasor. The process involves dividing the 120 by 50 to get 2.4 as the magnitude of the current. In phasor algebra, the sign of the angle in the denominator is changed and added to the angle of the numerator. This is the same process used to multiply and divide exponents. The angle $+37^\circ$ is changed to -37° and added to the angle in the numerator which is 0° . The angle of the current phasor is -37° ($-37^\circ + 0^\circ = -37^\circ$).

$$\text{Current} = \frac{120 \angle 0^\circ}{50 \angle +37^\circ} = 2.4 \angle -37^\circ$$

When multiplying two phasors, simply multiply the magnitude and add the angles as illustrated in the following example from Figure 221.5.

$$\text{Voltage} = \text{Impedance} \times \text{Current} = (50 \angle +37^\circ) \times (2.4 \angle -37^\circ) = 120 \angle 0^\circ$$

Conclusions: Inductive reactance and capacitive reactance is frequently present in ac circuits along with the resistance. All of these quantities have the units of Ohms but they cannot be added arithmetically. The capacitive reactance and inductive reactance have an opposite effect on a circuit and in the case of a series circuit they can simply be subtracted from one another to obtain the net reactance. The net reactance and resistance form the two sides of a right triangle and the impedance which is their combined effect on the circuit is the hypotenuse of that right triangle. Impedance can replace resistance in Ohm's law to determine the unknown quantity when either voltage or current of the circuit is known.

Converting from Rectangular Form to Polar Form: When an impedance is given in rectangular form such as in Figure 221.8 ($25 + j5$) it can be converted to polar form by using Equation 221.5 to obtain the magnitude, and Equation 221.12 to obtain the angle. The following is the impedance of the circuit of Figure 221.8 shown in polar form.

$$\text{Magnitude} = \sqrt{25^2 + 5^2} = \sqrt{650} = 25.5$$

$$\text{Angle}(\theta) = \tan^{-1} \frac{5}{25} = 11.3^\circ$$

$$Z_T = 25 + j5 = 25.5 \angle 11.3^\circ$$

Converting From Polar Form to Rectangular Form: To convert an impedance from polar form to rectangular form requires the use of Equation 221.8 and Equation 221.9 rearranged as follows:

$$\text{Resistance (R)} = \text{Side adjacent} = \cos \theta \times \text{hypotenuse}$$

$$\text{Reactance (X)} = \text{Side opposite} = \sin \theta \times \text{hypotenuse}$$

Example: If the impedance in polar form is $Z = 25.5 \angle 11.3^\circ$, converted to rectangular form the impedance is $Z = 25 + j5$.

$$R = \cos 11.3^\circ \times 25.5 = 25$$

$$X = \sin 11.3^\circ \times 25.5 = 5$$